



# **Electronic 790 Refrigerator / Freezer**

## **Model**

E522BLE G FP WW 13

## **Product Code**

21650-B





## PRODUCT

<b>Brand</b>	Fisher & Paykel
<b>Voltage</b>	220-240V 50Hz
<b>Model</b>	E522BLE G FP WW 13
<b>Product Code</b>	21650-B

**Fisher & Paykel Appliances Ltd**  
78 Springs Road, East Tamaki  
PO Box 58-732, Greenmount  
Auckland, New Zealand  
Telephone: 09 273 0600  
Facsimile: 09 273 0656

**Fisher & Paykel Australia Pty Ltd**  
A.C.N. 003 335 171  
19 Enterprise Street  
P O Box 798  
Cleveland, Queensland 4163  
Telephone: 07 3826 9100  
Facsimile: 07 3826 9164

**Fisher & Paykel Appliances Ltd U.K**  
Pheasant Oak Barn,  
Hob Lane, Balsall Common  
Warwickshire, CV7 7GX  
England  
Telephone: +44 1676 531 770  
Facsimile: +44 1676 531 771



# CONTENTS

DOORS.....	6
CABINET COMPONENTS .....	8
FAN, COVERS AND EVAPORATOR ASSEMBLIES.....	12
DISPLAY MODULE AND DUCT COVERS .....	14
ACTIVE SMART ST4 TERMINALS PLUGS & SOCKETS.....	16
COMPRESSOR, ANCILLARY COMPONENTS & CONTROL MODULE.....	18
NOTES .....	22
REFRIGERATION ABBREVIATION KEY .....	23

## GUIDE TO USING THIS MANUAL

The model covered by this manual is listed on the front cover.

The information detailed in this manual is subject to change without notice, the latest version is indicated by the reprint date and replaces any earlier editions.

The front cover picture shows the type of product and may not necessarily be an exact image of the models covered by the manual.

### Kit Parts

The components shown in *italics with a part number* are those parts in the kit which are available also as separate items. In addition, some parts may be supplied with this kit which are not available as separate items and are therefore either not listed or a part number is not shown against the part description in this manual.

All details relating to Technical Bulletins or Notes are shown on a dedicated page. The Technical Bulletin Number shown relates to the bulletin version which is produced for the Global Service Centres.

### Parts List Key

NOT USED	As a part, indicates the diagram part reference is not used in this manual.
#	Beside the part number, indicates the part is no longer available.
<i>italics</i>	Kit components or parts included are shown in <i>italics</i> , refer to above notes: Kit Parts
*	Indicates a Technical Bulletin or note exists for the part or part reference.
NI	As a part reference, indicates the part is not illustrated on the diagram.

# DOORS

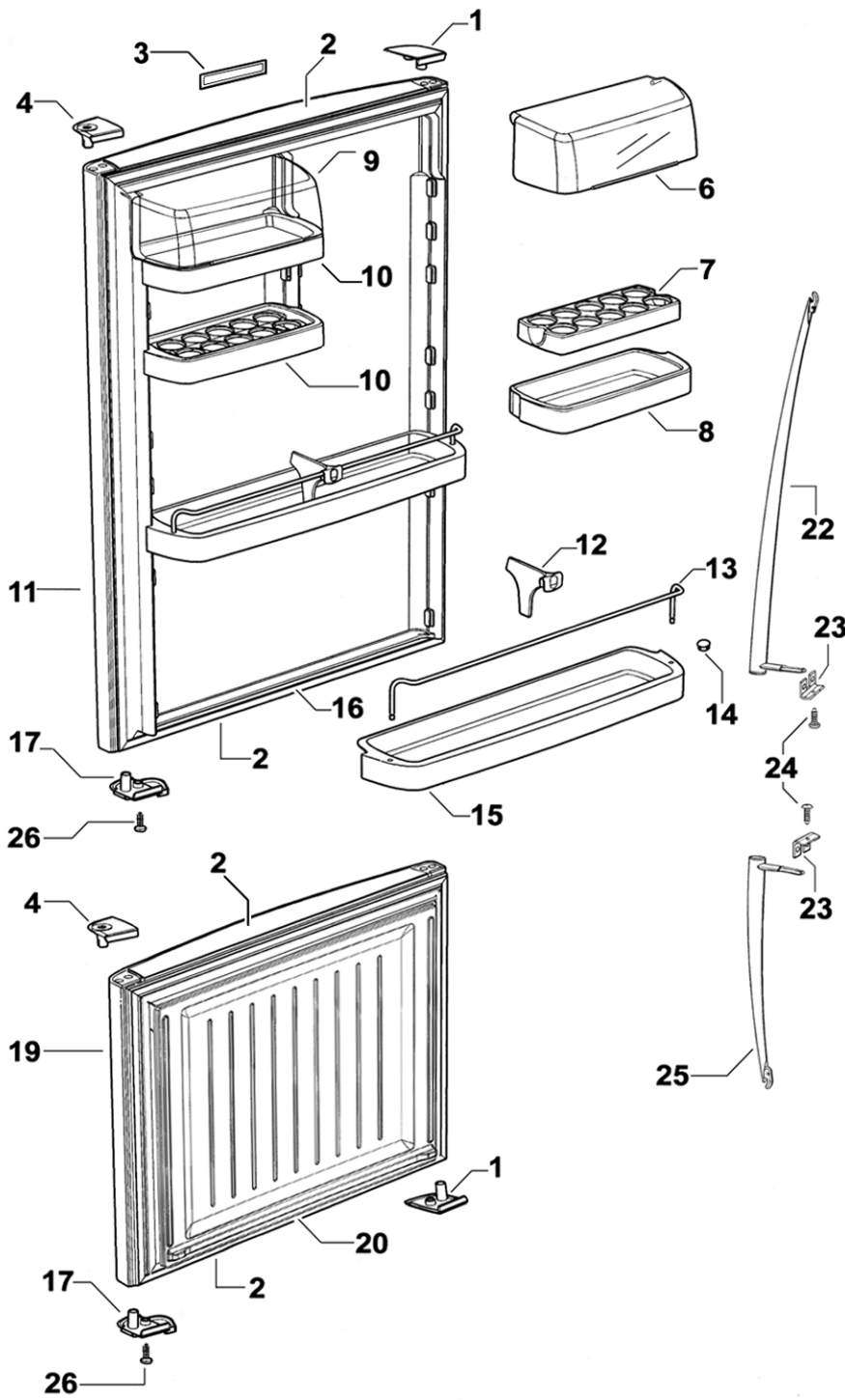

DWG000010

## DOORS

REF	PART	DESCRIPTION
1	883717	COVER HGE DR RHT/LHB WHITE LIP 680/790
	883718	COVER HGE DR LHT/RHB WHITE LIP 680/790
2	883672	CAP DOOR END OUTER WH 790
3	836790	NAMEPLATE F&P ELEG/TASMAN
4	883661	BEARING HINGE LH WH LIP 680/790
6	882141	COVER DOOR SHELF RH
7	882323	SHELF EGG RACK
8	882146	SHELF DOOR SML RH 790
9	882140	COVER DOOR SHELF 790 LH
10	882145	SHELF DOOR SML LH 790
11	300068P	DOOR PC WW 790X1030 LH CS HANP/C
12	883121	DIVIDER BOTTLE RAIL WHITE
13	881357	RAIL BOTTLE SUPPORT SATIN CHROME 790
14	876281	PLUG DOOR SHELF WHITE
15	882100	SHELF DOOR LARGE 790
16	883739P	GASKET ASSY E522B PC LGREY
17	881456	BEARING DR CLOSE LH WH 680/790
18	874706	LABEL FREEZER GUIDE BLUE 55 X 150
19	312075P	DOOR FC G WW 790X613 LH
20	883740P	GASKET ASSY E522B FC LGREY
22	813914	HANDLE DOOR CURVED LONG P/C
23	881391	PLATE HANDLE SUPPORT PLATED
24	881044P	SCREW 8X22 WAFER PHIL STZP (PKT 10)
25	813915	HANDLE DOOR CURVED SHORT P/C
26	881044P	SCREW 8X22 WAFER PHIL STZP (PKT 10)
NI	884466	BOOKLET USE & CARE FRIDGE EU

# CABINET COMPONENTS

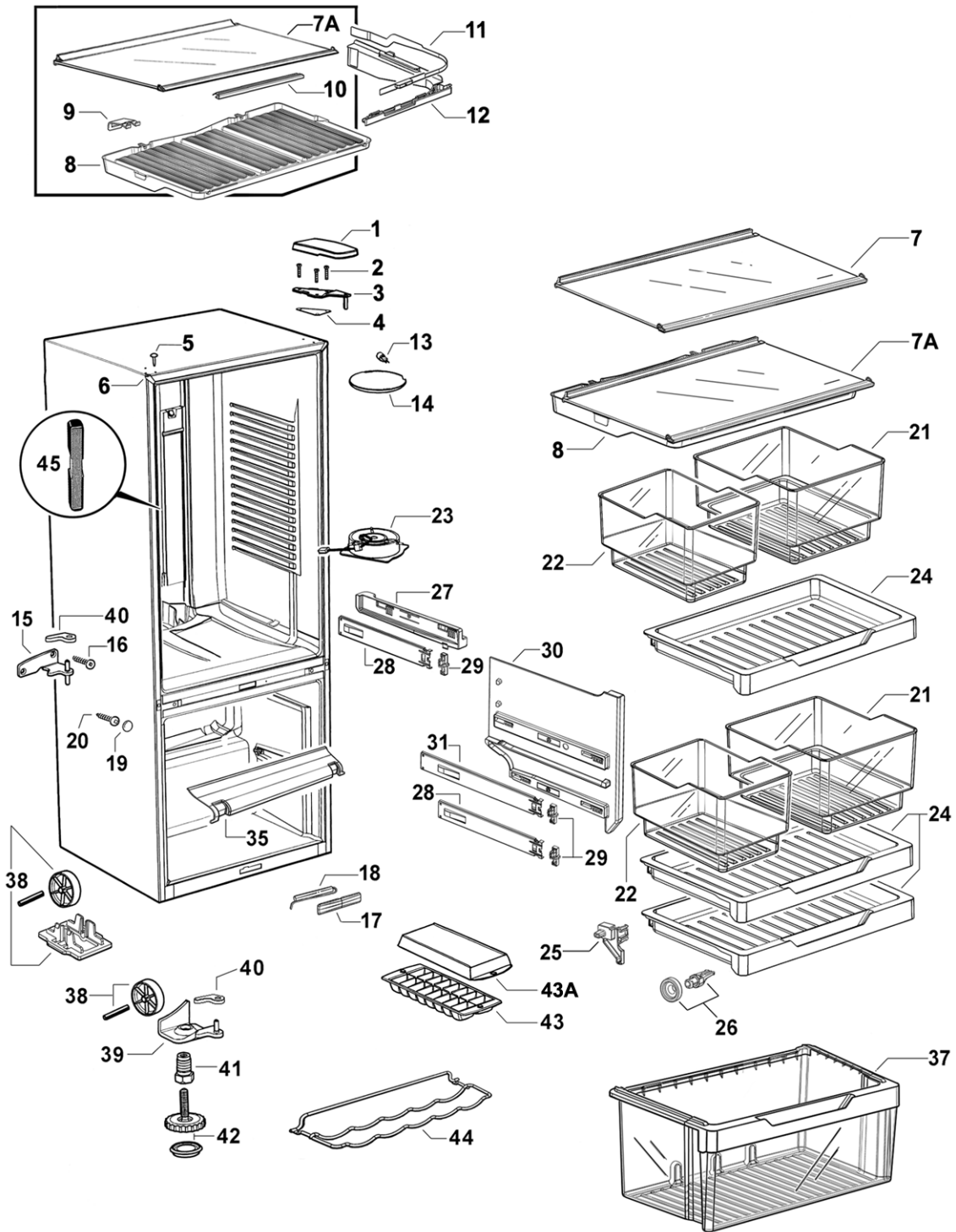



## CABINET COMPONENTS

REF	PART	DESCRIPTION
1	880490	COVER TOP HINGE WHITE
2	SP0282P	SCREW MC M5X20 HEX PH MS ZNPL (PKT 10)
3	880526	BRACKET TOP HINGE ASSY
4	882355	GASKET TOP HINGE
5	881131	PLUG TAPPED HOLE WHITE
6	883590	TRIM CORNER RECESSED WHITE
7	836751	SHELF GLASS PC 790 ASSY SC
	<i>Includes 836569</i>	<i>PLUG STIFFENER SHELF RH</i>
	<i>Includes 836570</i>	<i>PLUG STIFFENER SHELF LH</i>
	<i>Includes 836567</i>	<i>PLUG TRIM SHELF RH</i>
	<i>Includes 836568</i>	<i>PLUG TRIM SHELF LH</i>
	<i>Includes</i>	<i>TRIM SHELF PC 790 SC</i>
	<i>Includes</i>	<i>STIFFENER SHELF PC 790 SC</i>
	<i>Includes</i>	<i>SHELF GLASS PC 790</i>
7A	836728	SHELF GLASS HCL 790B ASSY SC
	<i>Includes 836569</i>	<i>PLUG STIFFENER SHELF RH</i>
	<i>Includes 836570</i>	<i>PLUG STIFFENER SHELF LH</i>
	<i>Includes 836567</i>	<i>PLUG TRIM SHELF RH</i>
	<i>Includes 836568</i>	<i>PLUG TRIM SHELF LH</i>
	<i>Includes 836582</i>	<i>RETAINER HCL FRONT 790</i>
	<i>Includes 881268</i>	<i>BRACKET HCL SUPPORT B GLASS SHELF (2)</i>
	<i>Includes</i>	<i>TRIM SHELF HCL 790 SC</i>
	<i>Includes</i>	<i>STIFFENER SHELF PC 790 SC</i>
	<i>Includes</i>	<i>SHELF GLASS PC 790</i>
8	836574	LID HUMIDITY CONTROL 790B
9	881268	BRACKET HCL SUPPORT B GLASS SHELF
10	836582	RETAINER HCL FRONT 790
11	836631	SLIDE CONTROL HUMIDITY RH
	836633	SLIDE CONTROL HUMIDITY LH
12	836632	GUIDE CONTROL HUMIDITY RH
	836634	GUIDE CONTROL HUMIDITY LH
13	874017	LAMP HALOGEN PC
14	875318	COVER LAMP PC
15	881286	BRACKET CENTRE HINGE LH
16	880656P	SCREW 10GX25CSK SQ SS (PKT 10)
17	881420	COVER REED SWITCH ST4 WHITE
18	881223P	SWITCH REED FIELD FIX KIT ST4
19	880595	CAP SCREW CROSS RAIL WHITE
20	880655P	SCREW #10X19 AB #2 SQ ZN NP (PKT 10)
21	836524	BIN SMALL790
22	836522	BIN SMALL
23	884518P	FAN & HOUSING PC ASSY
	<i>Includes</i>	<i>CONNECTOR IDC UP2 (2)</i>
	<i>Includes</i>	<i>LABEL WARNING 12 VOLT DC</i>
	<i>Includes</i>	<i>FAN &amp; HOUSING PC ASSY</i>

Continued next page

# CABINET COMPONENTS

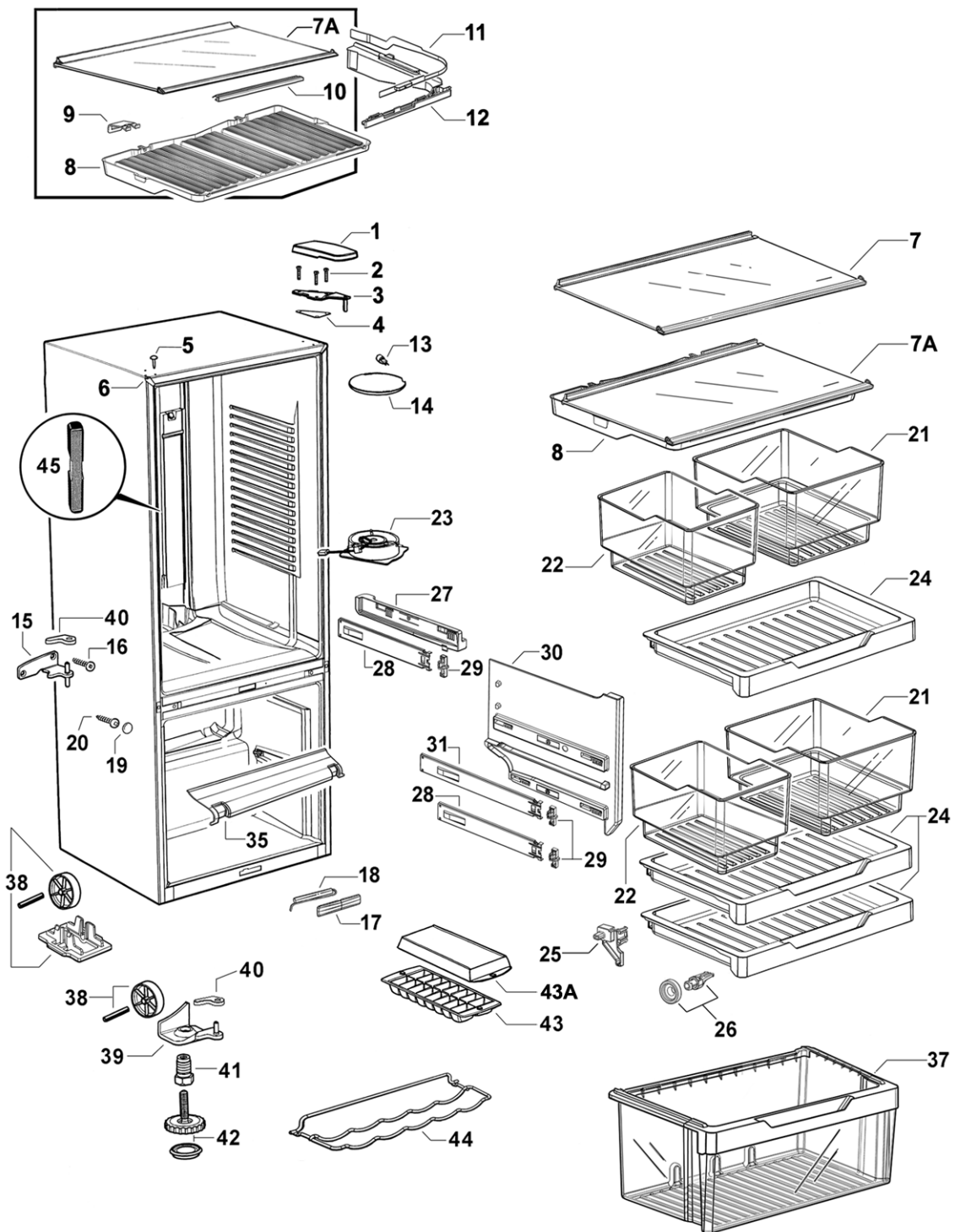

## CABINET COMPONENTS

REF	PART	DESCRIPTION
NI	875110	GASKET INSULATION FAN PC
24	836514	TRAY 790
25	836585	SKID TRAY RH
	836586	SKID TRAY LH
26	836517	WHEEL & CHASSIS ASSEMBLY (PKT 2)
27	836810	RETAINER & SLIDE 790 RH ASSY
	<i>Includes</i>	<i>RETAINER SLIDE PC RH</i>
	<i>Includes 836700</i>	<i>SLIDE 305 RH ASSEMBLY</i>
	<i>Includes 836520</i>	<i>CLIP SLIDE</i>
	836809	RETAINER & SLIDE 790 LH ASSY
	<i>Includes</i>	<i>RETAINER SLIDE PC LH</i>
	<i>Includes 836701</i>	<i>SLIDE 305 LH ASSEMBLY</i>
	<i>Includes 836520</i>	<i>CLIP SLIDE</i>
28	836700	SLIDE 305 RH ASSEMBLY
	<i>Includes 836520</i>	<i>CLIP SLIDE</i>
	836701	SLIDE 305 LH ASSEMBLY
	<i>Includes 836520</i>	<i>CLIP SLIDE</i>
29	836520P	CLIP SLIDE (PKT 2 )
30	836545	RETAINER SLIDE FC RH
	836546	RETAINER SLIDE FC LH
31	836702	SLIDE 350 RH ASSEMBLY
	<i>Includes 836520</i>	<i>CLIP SLIDE</i>
	836703	SLIDE 350 LH ASSEMBLY
	<i>Includes 836520</i>	<i>CLIP SLIDE</i>
35	836595	DUCT RETURN AIR FC 790
37	836661P	BIN ASSEMBLY LARGE 790
	<i>Includes</i>	<i>HANDLE BIN LARGE</i>
38	315090P	KIT WHEEL BRACKET CLIP
	<i>Includes</i>	<i>PIN ROLLER PLATED</i>
	<i>Includes</i>	<i>ROLLER FOOT FRONT</i>
	<i>Includes</i>	<i>CLIP WHEEL BRACKET</i>
39	881277	BRACKET BTTM HINGE LH ASSY PLATED
40	883989	CAP DOOR CLOSING HGE BRKT GY LH
41	880959	BOLT BTTM HINGE BRKT
42	880512	FOOT LEVELLING ASSEMBLY
	<i>Includes 880519</i>	<i>BASE LEVELLING FOOT</i>
43	874107	TRAY ICE BASE
43A	874108	TRAY ICE LID
44	NOT USED	
45	NOT USED	
<b>JOINER KIT FOR SIDE BY SIDE CABINET CONNECTION</b>		
Used for combining any of the the following 1695mm high cabinet models: N388 ,C450, E402B, E411T, E415H, E440T, E442B, E521T and E522B		
NI	813835	KIT JOINER WHITE

## FAN, COVERS AND EVAPORATOR ASSEMBLIES

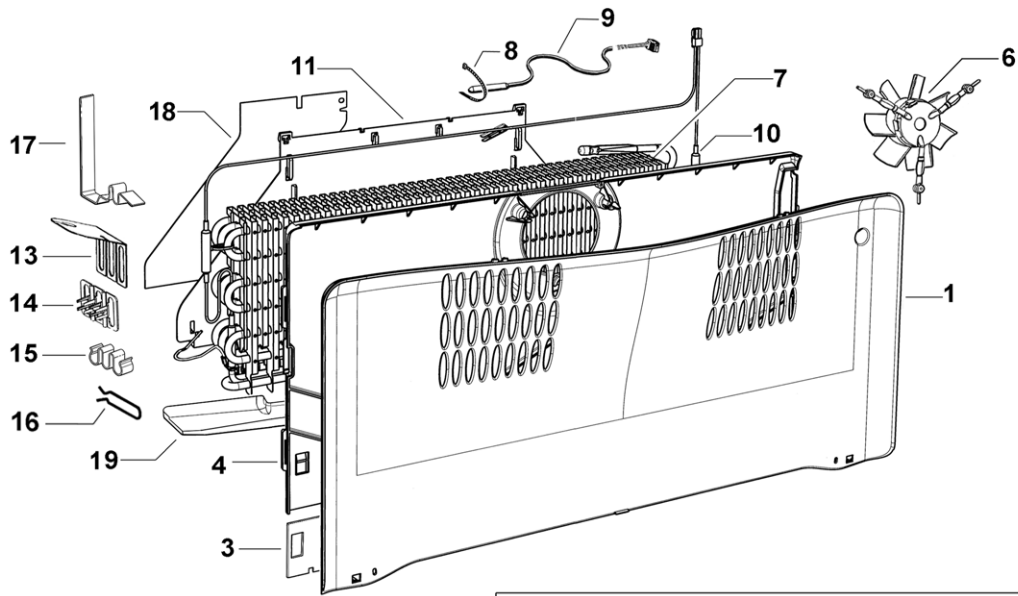

**BOTTOM FREEZER MODEL E522B  
WITH TWIN PC RETURN AIR DUCT SYSTEM**

## FAN, COVERS & EVAPORATOR ASSEMBLIES

REF	PART	DESCRIPTION
1	873395	COVER FAN FC FRONT E790B
3	883783	SHIELD FC REAR COVER
4		COVER FAN FC REAR 790 (Part of 306096P Kit)
	306096P	FAN FC KIT 790 SERIES A to C
	<i>Includes 880279</i>	<i>SHIELD HEATER FC COVER</i>
	<i>Includes</i>	<i>COVER FAN FC REAR 790</i>
	<i>Includes</i>	<i>CONNECTOR IDC IDC UP2 (2)</i>
	<i>Includes</i>	<i>LABEL WARNING 12 VOLT DC</i>
	<i>Includes</i>	<i>FAN DC SUSPENDED FC ASSY</i>
6		FAN DC SUSPENDED FC ASSY (Part of 306096P Kit)
7	881437P	EVAPORATOR SERV KIT 790 ST4.2 (DEFROST HEATER NOT INCLUDED)
	<i>Includes 883863</i>	<i>JOINER CAPILLARY</i>
	<i>Includes 883864</i>	<i>CAPILLARY SHORT 200MM</i>
	<i>Includes 855305</i>	<i>HARNESS ADAPTOR DFROST</i>
	<i>Includes 883349</i>	<i>CLIP DEFROST HEATER B MODEL EVAP (2)</i>
	<i>Includes 883350</i>	<i>CLIP DEFROST HEATER T MODEL EVAP</i>
8	900325	TIE PLASTIC 140MM
9	855203P	SENSOR KIT ASSY
	<i>Includes</i>	<i>HEATSHRINK 1/8" MW ADHESIVE LINED</i>
	<i>Includes</i>	<i>HARNESS SENSOR PC</i>
10	884125P	HEATER DEF & FUSE YELL LEAD 790 240V (EXTENDED HOT TAIL)
	<i>Includes 883349</i>	<i>CLIP DEFROST HEATER B EVAP (1)</i>
	<i>Includes 883350</i>	<i>CLIP HEATER DEFROST T EVAP (2)</i>
	<i>Includes 883756</i>	<i>LEAFLET INSTRUCTION 790B DEF HTR</i>
	<i>Includes 855305</i>	<i>HARNESS ADAPTOR DEFROST</i>
	<i>Includes 900325</i>	<i>TIE PLASTIC 140MM (2)</i>
11	884314	CHASSIS EVAPORATOR ELECT 790B MODEL
13	880724	DEFLECTOR AIR FLOW
14	871463	CLIP TUBE EVAP PLASTIC
16	855299	CLIP HEATER 20MM EVAP FIN (2)
17	883349	CLIP DEFROST HEATER B MODEL EVAP
18	884315	DEFLECTOR HEAT (2)
19	884316	SHIELD DRAIN 790B

# DISPLAY MODULE AND DUCT COVERS

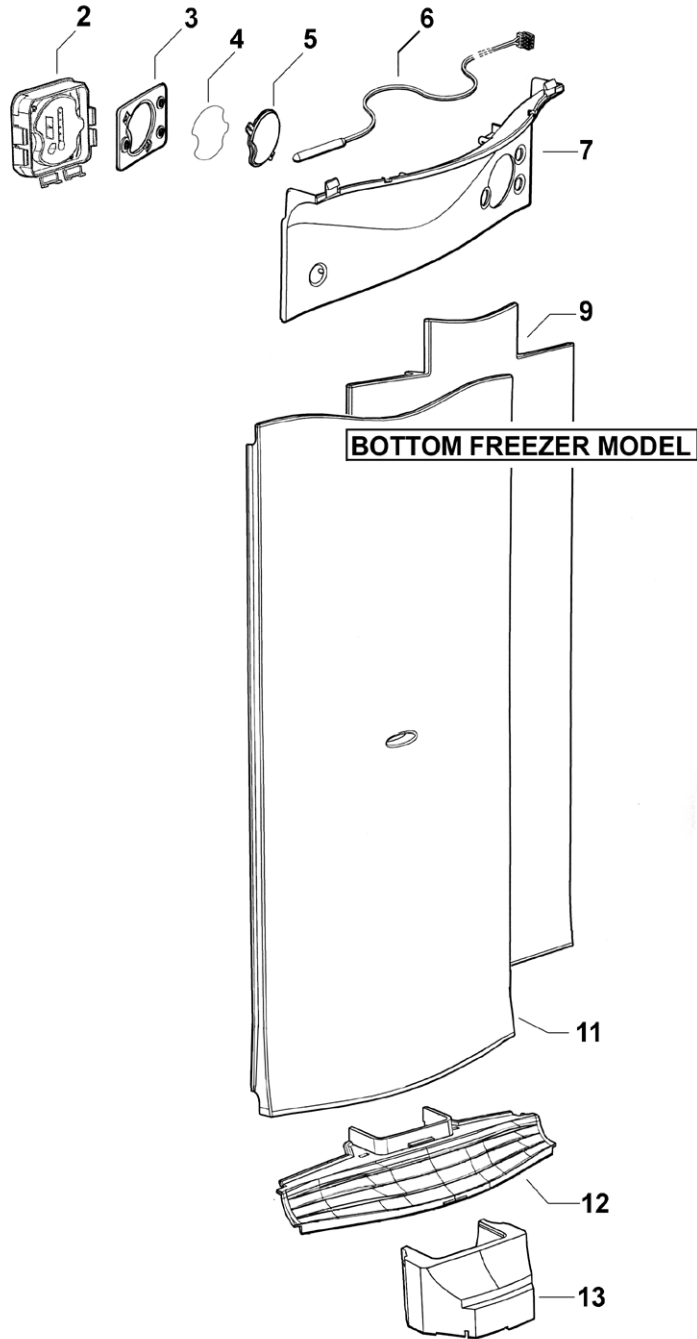

## DISPLAY MODULE AND DUCT COVERS

REF	PART	DESCRIPTION
2	881218P	MODULE DISPLAY – BC ST4
3	880779	GASKET DISPLAY MODULE
4	883448	INSERT GRAPHICS DISPLAY
5	883449	LENS CLEAR-DISPLAY MODULE
6	855203P	SENSOR KIT ASSY
	<i>Includes</i>	<i>HEATSHRINK 1/8" MW ADHESIVE LINED</i>
	<i>Includes</i>	<i>HARNESS SENSOR PC</i>
7	836764	COVER DUCT TOP PC B
9	873950	INSULATION COVER DUCT LG B
11	881191	COVER DUCT LONG B SGLE SLOT LONG
12	813287	GRILLE PC RETURN AIR B MODEL (6 Open Vents)
13	872833	INSULATION INSERT PLUG-IN-DIVIDER B MODELS

# ACTIVE SMART ST4 TERMINALS PLUGS & SOCKETS

## ACTIVE SMART STAGE 4 TERMINALS, PLUGS AND SOCKETS

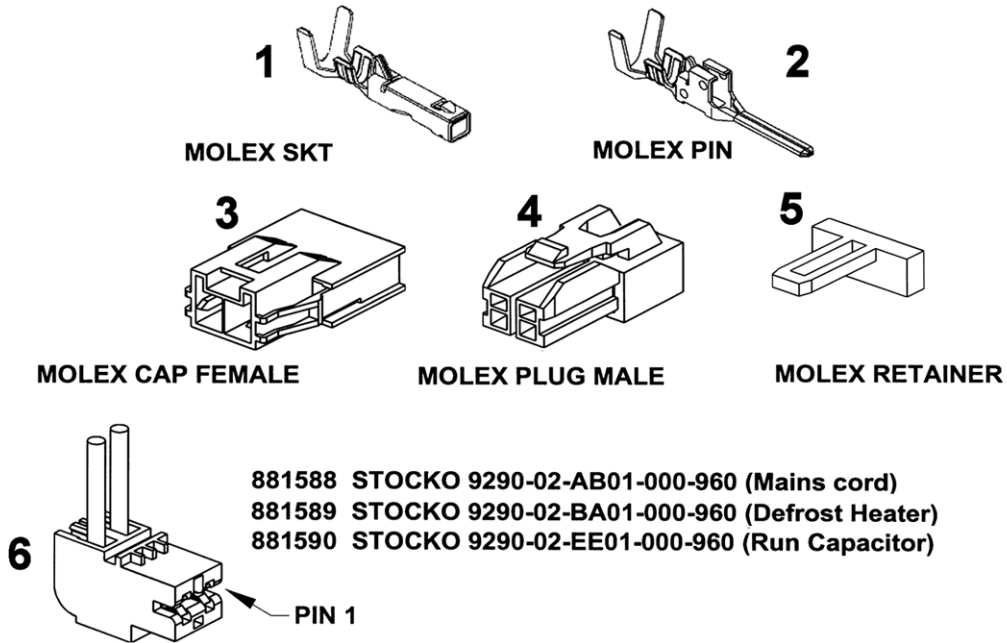

NOTE THAT IN THE PART NAMES OF THESE CONNECTORS, THE -02- REFERS TO IT BEING A 2 WAY CONNECTOR, AND THE -AB01- (FOR EXAMPLE) REFERS TO THE CODING OF THE CONNECTOR. STOCKO IS THE MANUFACTURER OF THESE CONNECTORS.

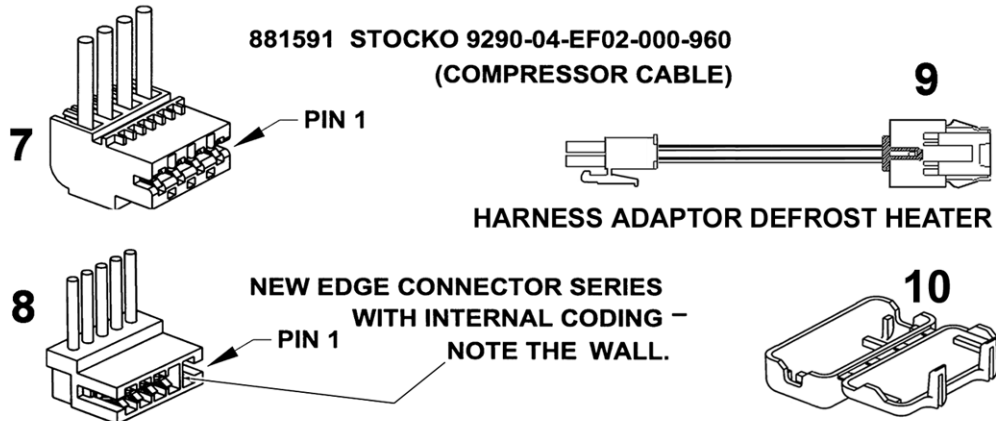

NOTE: TO MINIMISE THE NUMBER OF SPARE PARTS THAT NEED TO BE CARRIED, THESE CODED CONNECTORS ARE TO BE REPLACED WITH THEIR UN-CODED EQUIVALENTS. FOR THE 3, 5 AND 6 WAY CONNECTORS USED ON STAGE 4 CABINETS



## ACTIVE SMART ST4 TERMINALS PLUGS & SOCKETS

REF	PART	DESCRIPTION
1	881595	SOCKET 16-22AWG 50597-8100 MLX
	881596	SOCKET 20-26AWG 50598-8100 MLX
2	881597	PIN 16-22AWG 50599-8100 MLX
	881598	PIN 20-26AWG 50600-8100 MLX
3	881592	CAP FEMALE 51139-0200 MLX
4	881593	PLUG MALE 51138-0200 MLX
5	881594	RETAINER 51140-0205 MLX
6	881588	CONNECTOR RAST 9290-02-AB01
	881589	CONNECTOR RAST 9290-02-BA01
	881590	CONNECTOR RAST 9290-02-EE01
7	881591	CONNECTOR RAST 9290-04-EF02
8	873243	CONNECTOR RAST 7234-012-500
	873247	CONNECTOR RAST 7234-006-500
	873248	CONNECTOR RAST 7234-010-500
	873250	CONNECTOR RAST 7234-004-500
	873251	CONNECTOR RAST 7234-003-500
	873279	CONNECTOR RAST 7234-008-500
	881135	CONNECTOR RAST 7234-005-500
	881136	CONNECTOR RAST 7234-014-500
	881137	CONNECTOR RAST 7234-017-502
9	855305	HARNESS ADAPTOR DEFROST HEATER
10	884412	COVER PLUG MLX

NOTE: THE NUMBERS IN THE DESCRIPTION OF THE RAST CONNECTOR DENOTES THE NUMBER OF CONNECTIONS

EXAMPLE: 7234-017-502 =17 WAY CONNECTOR

# COMPRESSOR, ANCILLARY COMPONENTS & CONTROL MODULE

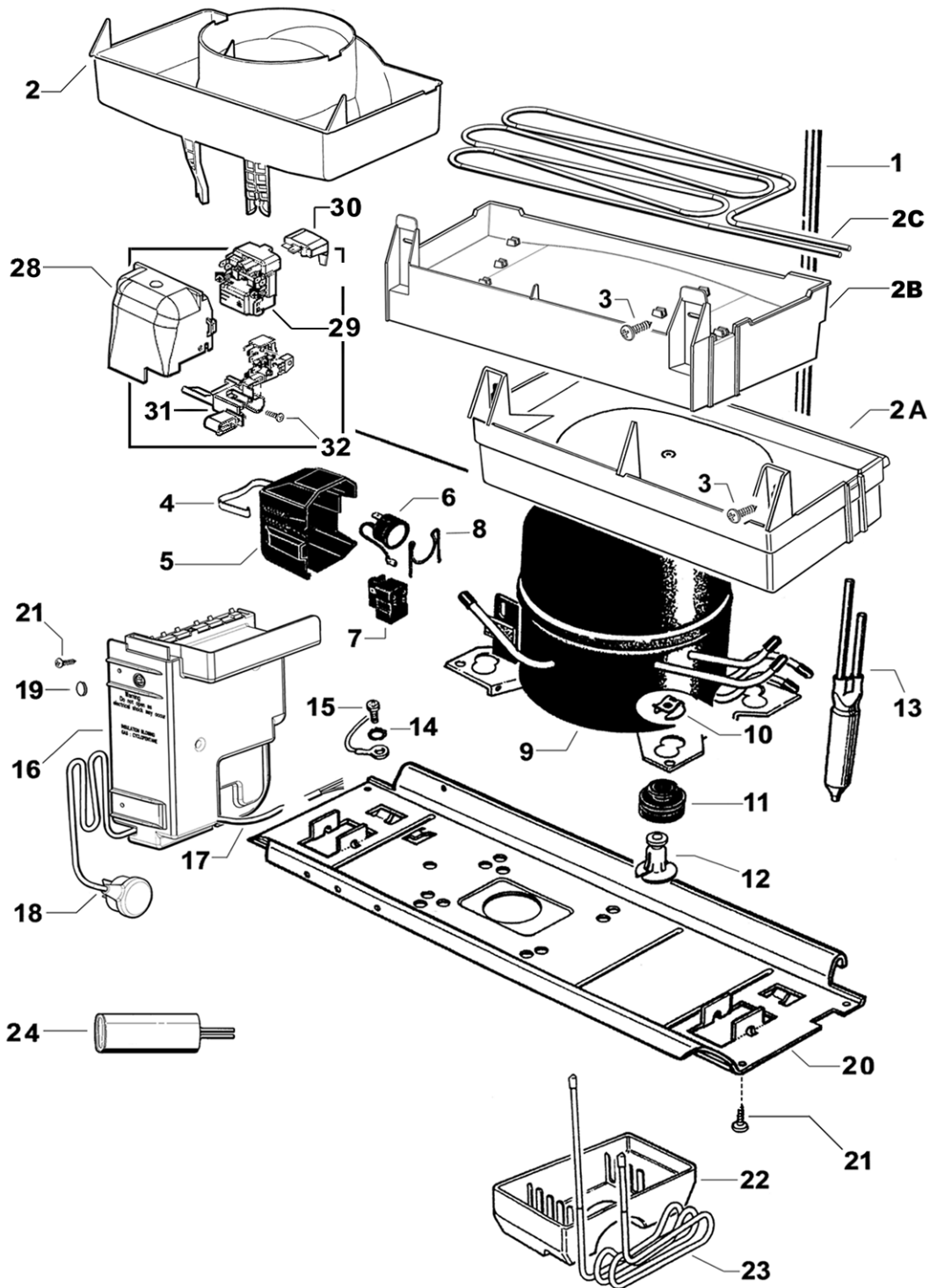

## COMPRESSOR, ANCILLARY COMPONENTS & CONTROL MODULE

REF	PART	DESCRIPTION
1	882137	PANEL BACK & CONDENSER ASSEMBLY
2	813435	TRAY WATER EVAP TOP HAT
2A	NOT USED	
2B	NOT USED	
2C	NOT USED	
3	SP0201P	SCREW 8X12 PAN PH NIB (PKT 10)
4	NOT USED	
5	NOT USED	
6	NOT USED	
7	NOT USED	
8	NOT USED	
9	207126P	COMPR MAT DGX86C15TAY 230-240V 50HZ
	<i>Includes 207131</i>	<i>RELAY PTC MAT M150MB3</i>
	<i>Includes 207143</i>	<i>O/LOAD MAT 734MFBYY DGX86</i>
	<i>Includes 207159</i>	<i>CAPACITOR RUN 2.5Uf 400VAC RAST5</i>
	▶ <i>Includes 207169</i>	<i>GROMMET COMPRESSOR MOUNTING 33M (4)</i>
	<i>Includes 207173</i>	<i>CAPACITOR START 45uf 400VAC (50mm x 116mm)</i>
	<i>Includes 207174</i>	<i>BRACKET HALF SADDLE 50mm</i>
	<i>Includes 209078</i>	<i>COVER PROTECTOR,</i>
	<i>Includes 209673</i>	<i>CLIP COVER 01-245233</i>
	<i>Includes 502173</i>	<i>FILTER DRIER 12 GR DUAL BRAZED</i>
	▶ <i>Includes 813421</i>	<i>PIN COMPRESSOR MOUNTING 33MM (4)</i>
	<i>Includes 813435</i>	<i>TRAY WATER EVAP TOP HAT</i>
	<i>Includes 813393</i>	<i>HARNESS COMPRESSOR 4 CORE DGX</i>
	<i>Includes 855270</i>	<i>CLIP FOOT COMPRESSOR</i>
	<i>Includes 883201</i>	<i>TUBE CU 4.76X155 DBLE SWAGE</i>
	<i>Includes 901525</i>	<i>SCREW #8X12 SP PAN NIB ST ZP (2)</i>
	<i>Includes 813773</i>	<i>INSTRUCTION SHEET DGX SERIES</i>
10	855270	CLIP FOOT COMPRESSOR
11	207169	GROMMET COMPRESSOR MOUNTING 33mm
12	813421	PIN COMPRESSOR MOUNTING 33mm
<b>▶ IMPORTANT:- MUST BE USED WITH MATSUSHITA DGX COMPRESSORS</b>		
13	502173P	FILTER DRIER 12 GR DUAL BRAZED
14	900101P	WASHER LOCK NO 10 EXT SP ZP (PKT 10)
15	900377P	SCREW 8X32X8 TYPE 23 PAN PH ZP (PKT 10)
16	884519P	MODULE CONTROL 220-240V ST4.2 SP KIT
	<i>Includes 813212</i>	<i>INSTRUCTION SHEET ST4.2 CONTL MODULE KIT</i>
	<i>Includes 813236</i>	<i>INSTRUCTION SHEET ST4.2 DIAGNOSTIC</i>
	<i>Includes 884518</i>	<i>FAN &amp; HOUSING PC ASSY (OVER MOULDED FAN)</i>
	<i>Includes</i>	<i>MODULE CONTROL 220-240V ST4.2</i>
17	813393	HARNESS COMPRESSOR 4 CORE DGX
18	881402	CABLE SUPPLY EUROPE ST4
19	875861	PLUG PLASTIC LT GREY

Continued next page

# COMPRESSOR, ANCILLARY COMPONENTS & CONTROL MODULE

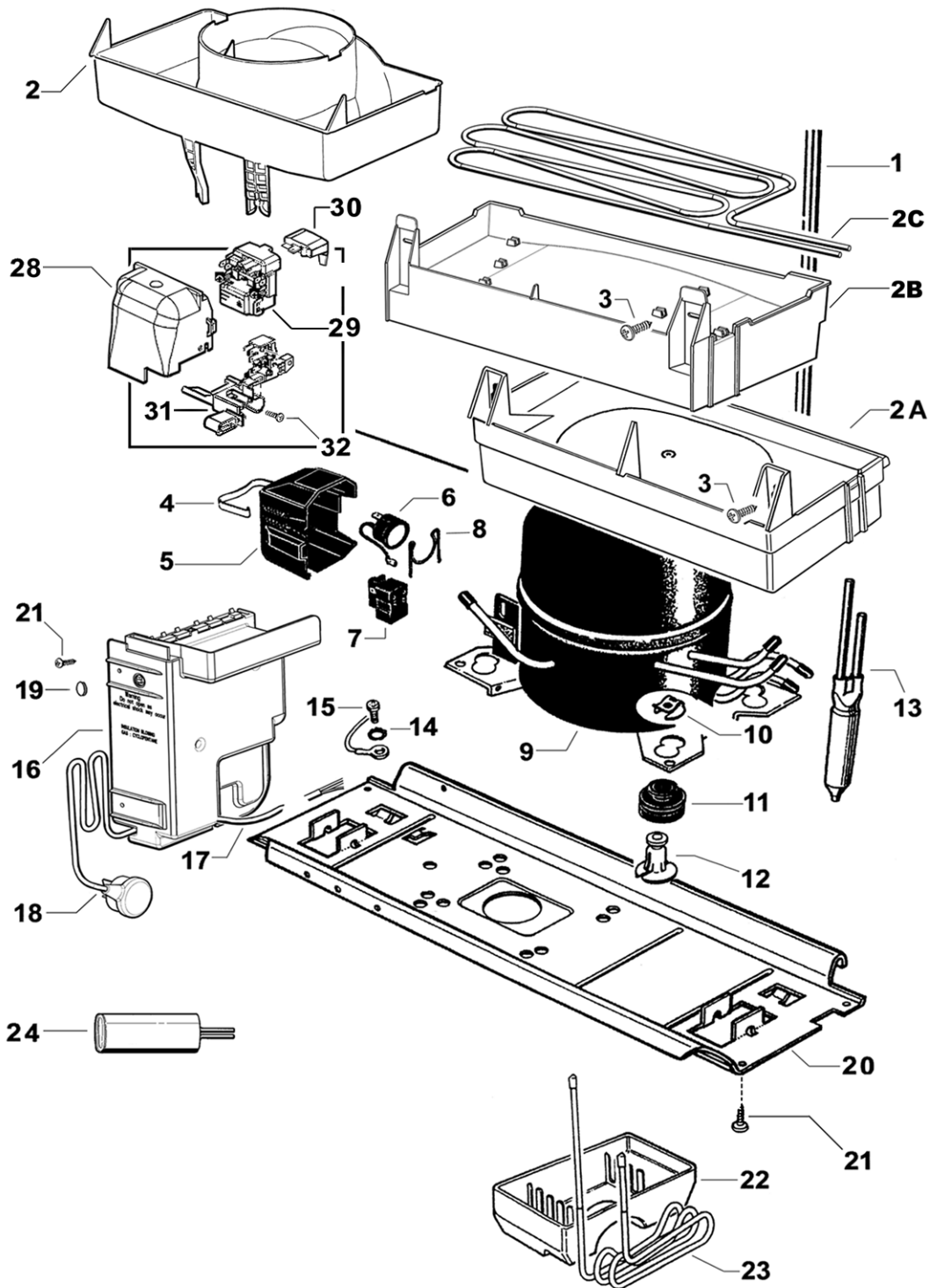

**COMPRESSOR, ANCILLARY COMPONENTS & CONTROL MODULE**

<b>REF</b>	<b>PART</b>	<b>DESCRIPTION</b>
20	878489	TRAY COMP MOUNTING 790
21	900475P	SCREW 8X16.4MM NIB STZP (PKT 10)
22	873228	TRAY WATER OVERFLOW
23	873040	TUBE HEATER SHEATHED 4.2MM
24	207173	CAPACITOR START 45uf 400VAC (50mm x 116mm)
	207159	CAPACITOR RUN 2.5Uf 400VAC RAST5 (25mm x 51mm) MATSUSHITA DGX COMPRESSOR 240V 50HZ
NI	207174	BRACKET HALF SADDLE 50mm
NI	881044P	SCREW #8X22 WAFER PH STZP (PKT 10)
28	209078	COVER PROTECTOR (DGX)
29	207131	RELAY PTC MAT 150MB3M24 DGX
30	207143	OVERLOAD MAT 734MFBYY DGX86
31	NOT USED	
32	NOT USED	
NI	874329	CABLE LEAD EARTH
NI	883874	SUCTION & CAPILLARY ASSY

## NOTES

## REFRIGERATION ABBREVIATION KEY

<b>10W</b>	<b>10 WATTS</b>
<b>12V</b>	<b>12 VOLTS</b>
<b>BC</b>	<b>BUTTER CONDITIONER</b>
<b>BS</b>	<b>“B” SERIES CABINET</b>
<b>CH</b>	<b>CHARCOAL COLOUR</b>
<b>DC</b>	<b>DIRECT CURRENT</b>
<b>DK GY</b>	<b>DARK GREY</b>
<b>F&amp;P</b>	<b>FISHER &amp; PAYKEL</b>
<b>FC</b>	<b>FREEZER COMPARTMENT</b>
<b>HAN P/C</b>	<b>HANDLE POWDER COATED</b>
<b>HC</b>	<b>HUMIDITY COMPARTMENT</b>
<b>HCL</b>	<b>HUMIDITY CONTROL LID</b>
<b>HS</b>	<b>HOT STAMPED</b>
<b>LH</b>	<b>LEFT HAND</b>
<b>LHB</b>	<b>LEFT HAND BOTTOM</b>
<b>LHT</b>	<b>LEFT HAND TOP</b>
<b>LT GY</b>	<b>LIGHT GREY</b>
<b>M5</b>	<b>5 MILLIMETER</b>
<b>MD GY</b>	<b>MID GREY</b>
<b>MEPS</b>	<b>MINIMUM ENERGY PERFORMANCE STANDARDS</b>
<b>PC</b>	<b>PROVISION COMPARTMENT</b>
<b>PUSHIN</b>	<b>PUSHIN TYPE GASKET</b>
<b>RH</b>	<b>RIGHT HAND</b>
<b>RHB</b>	<b>RIGHT HAND BOTTOM</b>
<b>RHT</b>	<b>RIGHT HAND TOP</b>
<b>SA or S/STONE</b>	<b>SANDSTONE COLOUR</b>
<b>SATIN OR SC</b>	<b>SATIN CHROME FINISH</b>
<b>SL or SIL</b>	<b>SILVER</b>
<b>SML</b>	<b>SMALL</b>
<b>SS</b>	<b>STAINLESS STEEL</b>
<b>X/RAIL</b>	<b>CROSS RAIL</b>
<b>XH9</b>	<b>TYPE OF DESSICANT WITHIN A FILTER DRIER</b>